

NANUK™



991

NEW NOUVEAU

3 POSSIBLE CONFIGURATIONS
CONFIGURATIONS POSSIBLES



LIFETIME WARRANTY
GARANTIE À VIE



IP67 WATERPROOF
ÉTANCHE À L'EAU IP67



MADE IN CANADA
FABRIQUÉ AU CANADA



MILITARY APPROVED
CERTIFIÉ MILITAIRE



CRUSHPROOF RESIN
RÉSINE INÉCRASABLE



The newest addition to our Long Series of premium, waterproof protective case, the 991 is our widest at over 20" (511mm) making it perfect for camera equipment like tripods and lighting, industrial equipment, rifles, guitars, RTK stations, bows, telescopes and lots of other long, wide equipment.

It's built to be fast and smooth with stainless steel ball-bearing wheels and three spring-loaded handles that make it the perfect low profile waterproof and dustproof hard case that can be thrown in a truckbed, stacked on a pallet, or helicoptered in for a photoshoot.

La toute dernière addition à notre longue série de valises de protection haut de gamme et étanches, la 991 est notre valise la plus large, mesurant plus de 20" (511 mm), ce qui la rend parfaite pour les équipements photographiques tels que les trépieds et l'éclairage, les équipements industriels, les fusils, les guitares, les stations RTK, les arcs, les télescopes et bien d'autres équipements longs et larges.

Elle est conçue pour être rapide et fluide, avec des roulettes à billes en acier inoxydable et trois poignées à ressort qui en font la valise rigide étanche et antipoussière, à profil bas, permettant d'être chargée dans un lit de camion, empilé sur une palette ou transporté en hélicoptère pour une séance photo.

SPECIFICATIONS | SPÉCIFICATIONS

Interior dimensions <i>Dimensions intérieures</i>	L44.56" x W17.13" x H8.38" L1131mm x W435mm x H212mm
Exterior dimensions <i>Dimensions extérieures</i>	L47.75" x W20.13" x H9.50" L1212mm x W511mm x H241mm
Weight <i>Poids</i>	10.9 kg 24.0 lbs
Lid depth <i>Profondeur du couvercle</i>	2.25" 57mm
Base depth <i>Profondeur de la base</i>	6.13" 155mm
Max buoyancy <i>Flottabilité maximum</i>	TBD
Temperature range <i>Plage de températures</i>	Min -20°F (-29°C) Max 140°F (60°C)
Airline cabin carry-on <i>Bagage de cabine</i>	No <i>Non</i>
Watertight <i>Étanche</i>	Yes - IP67 <i>Oui - IP67</i>
Warranty <i>Garantie</i>	Conditional lifetime guarantee <i>Garantie à vie conditionnelle</i>

ACCESSORIES | ACCESSOIRES



Set of 2 bottom corner caps
Ensemble de deux coins



Multilayer Solid Foam
Mousse en cube multicouches



ID Window
Plaque ID



TSA Approved Padlock
Cadenas TSA



Panel Installation Kit
Kit d'installation pour panneau



TSA Approved Latches
Fermeurs à serrures TSA



3 POSSIBLE CONFIGURATIONS CONFIGURATIONS POSSIBLES

If your needs change, the wheel rigs on the 991 are removable and can be replaced by our custom corner caps.

Si vos besoins changent, les supports de roue du 991 sont amovibles et peuvent être remplacés par nos capuchons de coin personnalisés.

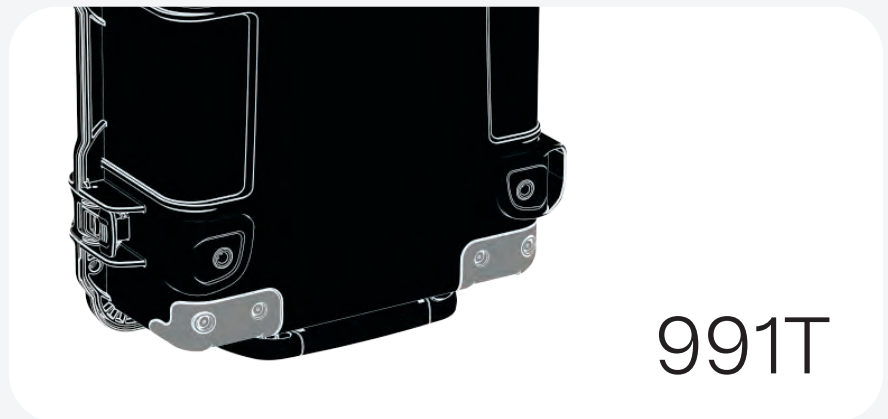

FEATURES | CARACTÉRISTIQUES

3 soft grip strong handles
3 poignées solides à prise souple

2 large and strong polyurethane wheels
2 roues larges et solides en polyuréthane

1 automatic pressure equalization valve
1 valve d'équilibrage automatique de la pression

Lower corner caps
Capuchons d'angle inférieur

Stackable
Empilable

991

991T

991M



CERTIFICATIONS | CERTIFICATIONS



DEF-STAN 81-41
DEF-STAN 81-41



IP6X Ingress protection dustproof
IP6X Indice de protection anti-poussière



IP7X Ingress protection Waterproof
IP7X Indice de protection étanche à l'eau



ASTM D-4169 DC-18 Drop Test
ASTM D-4169 DC-18 Test de chute



Mil-STD-810F Immersion
Mil-STD-810F Test d'immersion



MIL-STD-810G - Fungus Test
MIL-STD-810G - Test fongique



ATA Specification 300 Category 1 Impact
Spécification ATA 300 - Catégorie 1 test d'impact

MATERIALS | MATÉRIAUX

Case Shell - NK-7 High Impact Polypropylene
Coquille de la mallette - NK-7 Polypropylène résistant aux chocs

Latches - Nylon 66
Fermoirs - Nylon 66

Handle - NK-7 High Impact Polypropylene | TPE
Poignée - NK-7 Polypropylène résistant aux chocs | TPE

Purge Valve - Nylon 66 | Gore Membrane | Silicone Washers
Valve d'équilibrage - Nylon 66 | Membrane Gore® | Rondelles en silicone

Pins/Hardware - 304 Stainless Steel
Tiges/quincaillerie - Acier inoxydable 304

Gasket - EPDM
Joint d'étanchéité - EPDM

Wheels - Polyurethane | Polycarbonate
Roues - Polyuréthane | Polycarbonate



North America Headquarters

Plasticase Inc.
1059 Boulevard des Entreprises Ouest
Terrebonne, Québec, Canada J6Y 1V2

T: 450.628.1006 | 1.800.783.6883

E: info@nanuk.com
www.nanukcases.ca

Plasticase USA Inc./NANUK

2915 Ogletown Road
Newark, Delaware,
19713 USA

T: 450.628.1006 | 1.800.783.6883

E: info@nanuk.com
www.nanuk.com

NANUK EU B.V. NANUK Europe

Burg. J.G. Legroweg 96
9761TD Eelde,
The Netherlands

T: +31 50 3128694

E: info@nanuk.eu
www.nanuk.eu

NANUK™

✓ LIFETIME WARRANTY

✓ MILITARY APPROVED

991 FEATURES CARACTÉRISTIQUES



2 Large and Strong Polyurethane Wheels
2 grandes et solides roues en polyuréthane



Highly Stackable
Hautement empilable



8x M8 Threaded Steel Inserts
8x inserts filetés en acier M8



6x Powerclaw Latches
6x loquets Powerclaw



3 Soft Grip Strong Handles
3 poignées solides à prise souple



ID Window Compatible (Optional)
Compatible avec fenêtre d'identification (en option)